

100Tii TIMBER FLOOR/DECK

For 100Tii20CO, 100Tii20MTL, 100Tii30MTL, 100TiiCo30, 100TiXi20MTL, 100Tii40MTL.

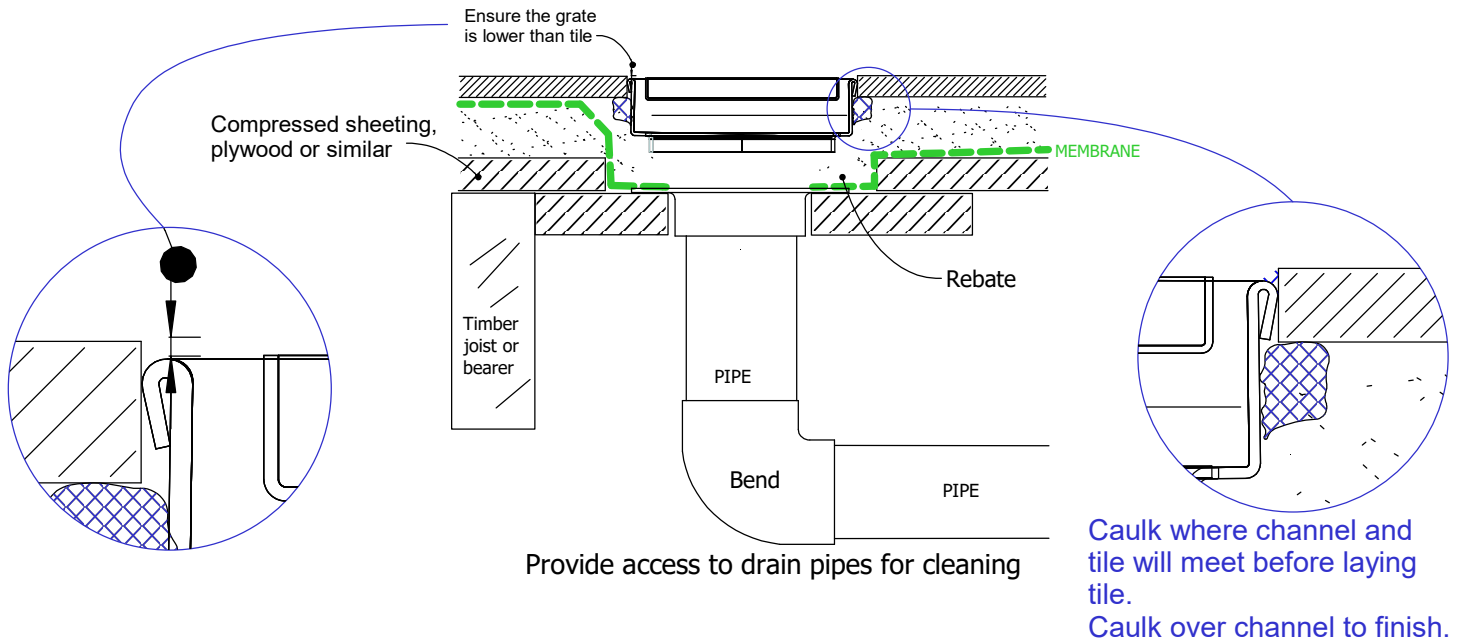

When 100Tii is running parallel to joist/bearer



When 100Tii is running perpendicular to joist/bearer

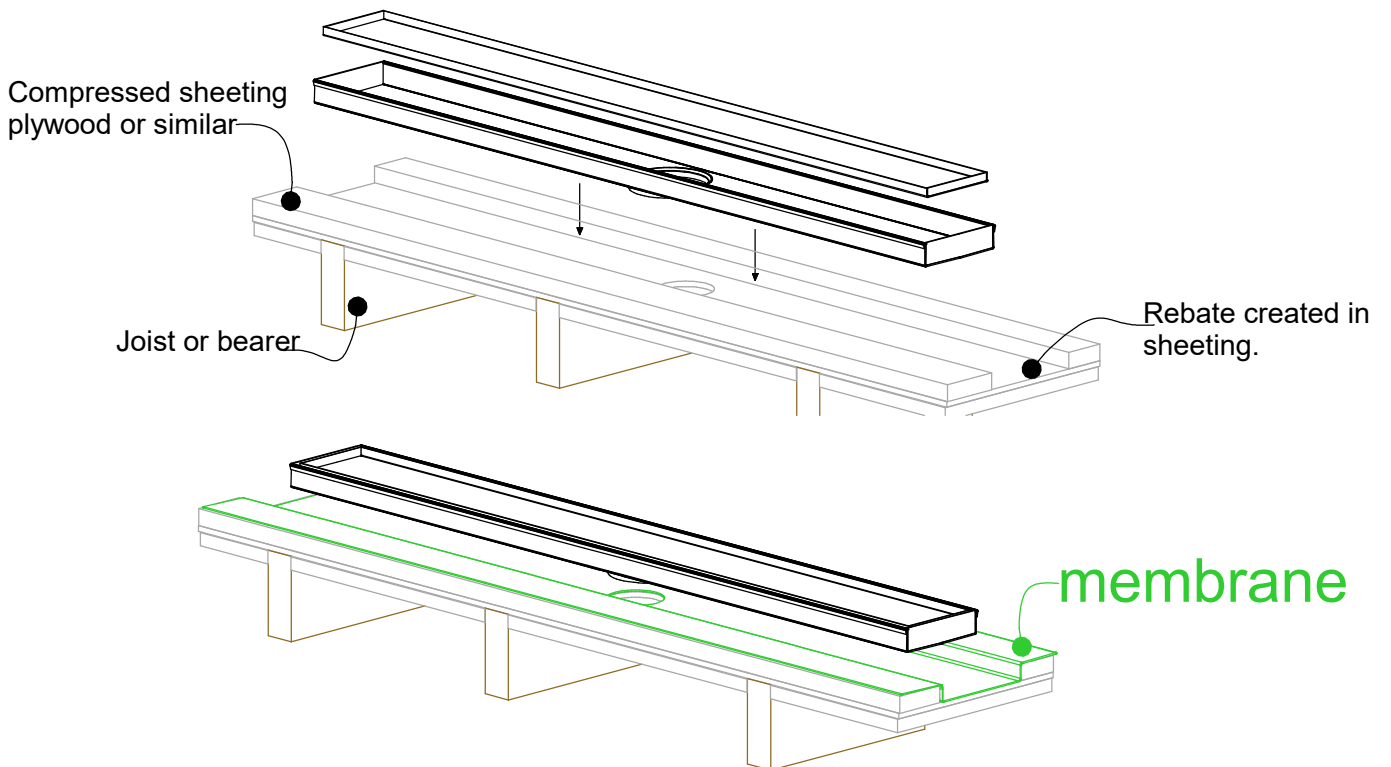

NOTE: For exterior application allow for expansion of 1mm per 3 metres by using quality suitable flexible sealant on channel joins.

